

Solar Storage Inverter

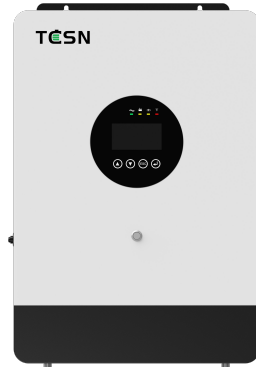

Introduce

Solar energy storage inverter features an industrial design with a modern aesthetic, easy to install and operate. It supports pure sine wave output and MPPT intelligent management for stable and reliable power supply, ideal for home energy storage, emergency power backup and household electrical appliances.



Reliable and long-lasting

Easy and quick maintenance
Design life: 15 years



Safe and worry-free

Lithium Battery Activation &
Wake-Up Protection:
OTP / OLP / OVP / OCP / SCP



Quick Installation

Industrial design with
modern aesthetic
Easy to install and operate



Integrated Functions

Supports RS485 / USB
WiFi wireless network (optional)



High Efficiency

High power density, low cost
Typical switching time: 10ms

System Management Diagram

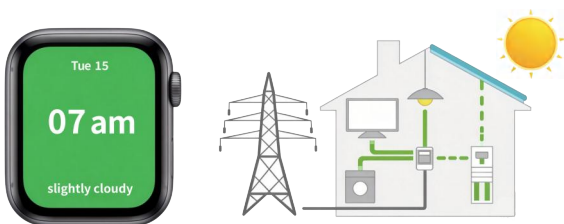
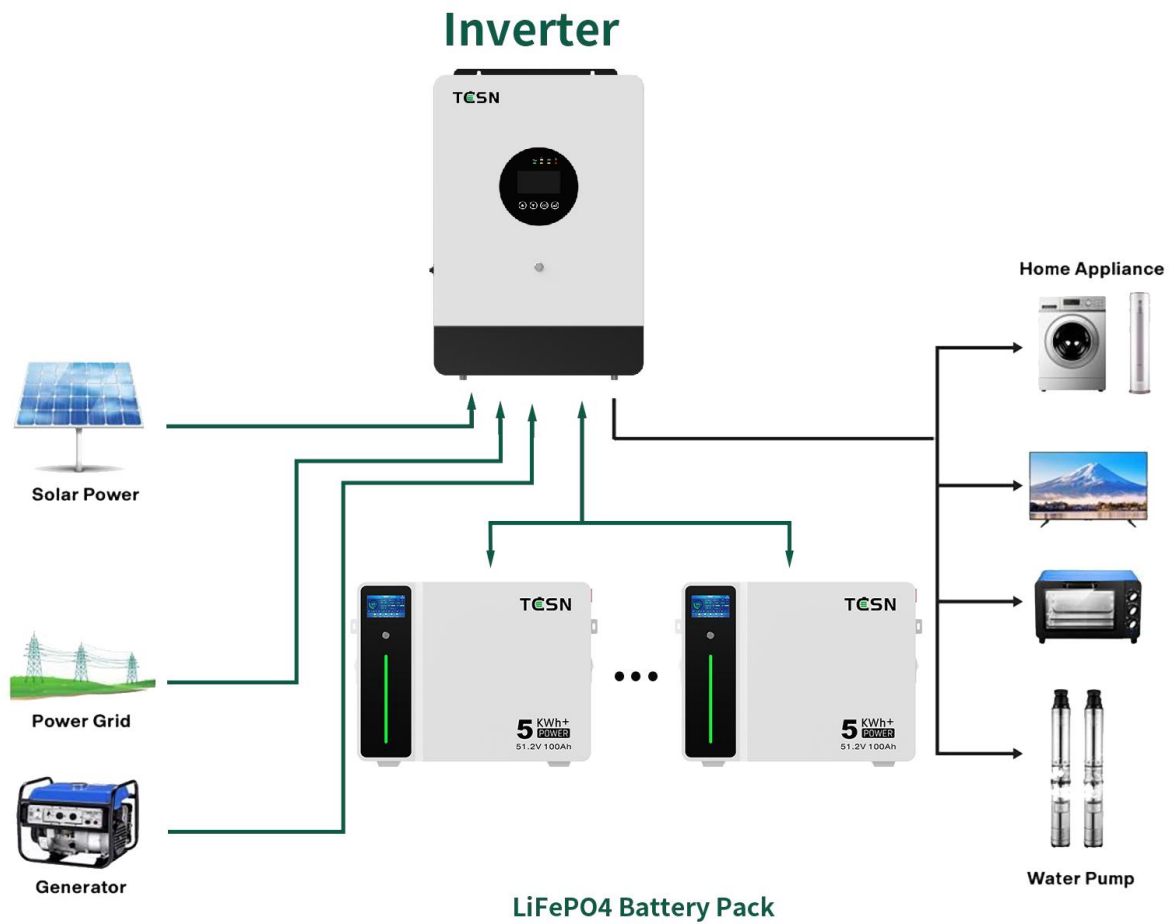

Solar energy is best used to power household appliances, with any excess energy stored in the battery.

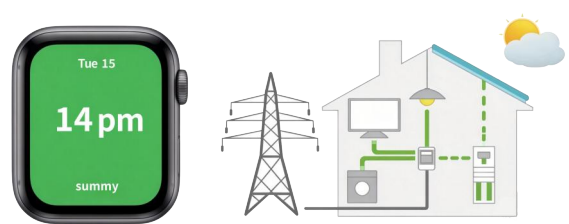

During the day, when there is insufficient light, the energy stored in the battery will be used to supplement the power supply.



At night, the energy stored in the battery powers household appliances.



When the stored energy in the battery is depleted, the public grid supplies power to household appliances.

Specifications

| | |
|---------------------------------------|---|
| Model | SPI B24-3K |
| AC Input | |
| Rate Input Voltage(VAC) | 208/220/230/240;L+N+PE |
| Voltage Range(VAC) | 90~280±3 (normal mode) ; 170~280±3 (UPS mode) |
| Frequency(Hz) | 40~70 (Default) |
| AC Output | |
| Rated Capacity(kW) | 3.6 |
| Voltage Regulation | ≤5% |
| Rate Voltage(VAC) | 208/220/230/240;L+N+PE |
| Power Factor(PF) | 1 |
| Frequency | Line Mode:Synchronized range, Battery Mode:50/60Hz±0.1% |
| Transfer Time(ms) | 10ms(Typical) |
| Harmonic Distortion | ≤3% (Linear Load) , ≤5% (Non-linear Load PF=0.7) |
| OverLoad Capacity (Battery Mode) | 60s@102%~110%load;10s@110%~130%load; 3s@130%~150%load;0.2s@>150%load |
| Max.Efficiency(Battery Mode) | 92%@24VDC |
| Prallel | Nonsupport |
| Charger(PV/AC) | |
| Solar Charger Type | MPPT |
| Max PV input power(W) | 5000 |
| PV Voltage Accuracy | ±2% |
| MPPT tracking range (VDC) | 40~450 |
| Efficiency | 99.5 MAX |
| Max PV voltage(VDC) | 500 |
| Max PV current(A) | 100 |
| Charger(AC Mode) | |
| Max AC Charge Current(A) | 100 |
| Charging voltage(VDC) | Settable:28~29V |
| Battery | |
| Battery type | Lithium-ion/VRLA/Custom |
| Battery over Voltage Protection (VDC) | 30.5 |
| Battery under voltage Protection(VDC) | 21 |
| Interface | |
| HMI | LCD |
| Monitoring | WiFi(Optional) |
| General Data | |
| Ingress Protection | IP20 |
| Operating Temperature | 0~50°C |
| Relative Humidity | 20%~95%(Non-condensing) |
| Storage Temperature | -15°C~60°C |
| Net Weight(kg) | 8.5 |
| Dimensions(W*D*H) | 315×456×120mm |
| Max.Operating Altitude | 4000m(Derating above 1000m) |
| Noise Emission | ≤50dB |